

Dec. 26, 1967

E. E. HEADRICK

3,359,678

FLYING SAUCER

Filed Nov. 1, 1965

2 Sheets-Sheet 1

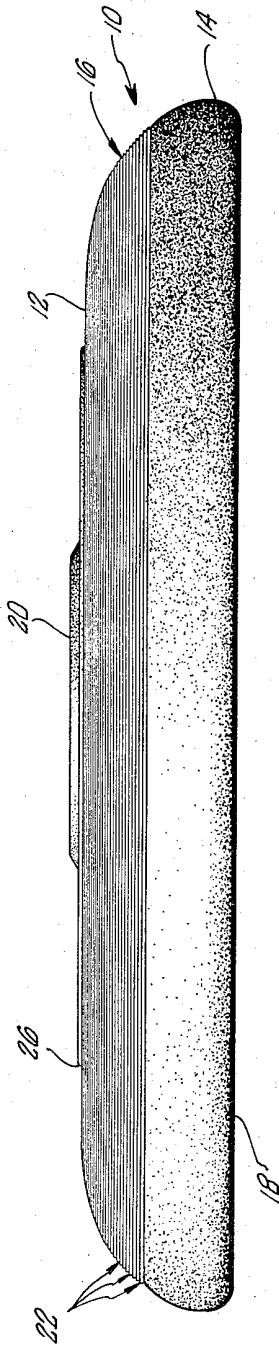

FIG. 1-

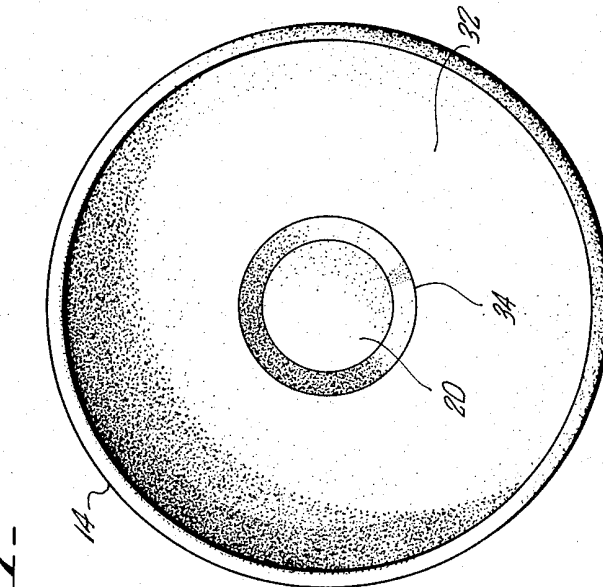

FIG. 3-

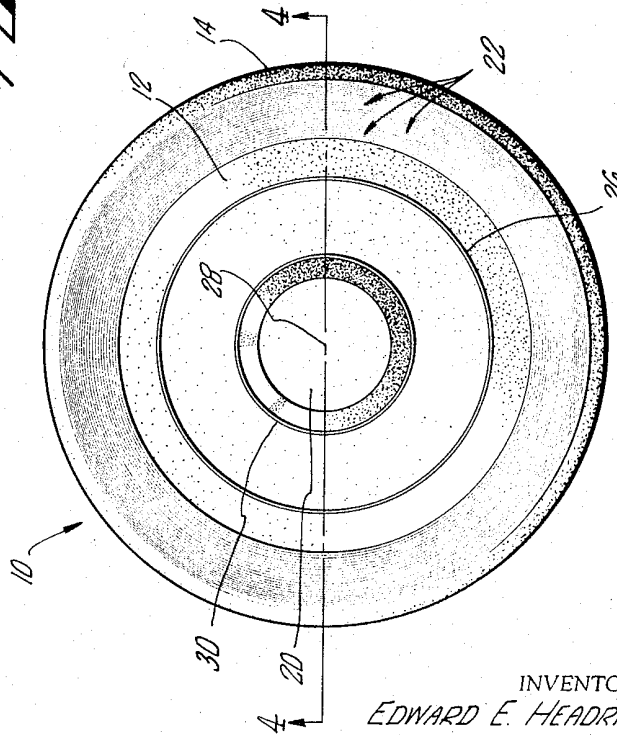

FIG. 2-

INVENTOR  
EDWARD E. HEADRICK  
BY  
*Christie, Parker & Hale*  
ATTORNEYS

Dec. 26, 1967

E. E. HEADRICK

3,359,678

FLYING SAUCER

Filed Nov. 1, 1965

2 Sheets-Sheet 2

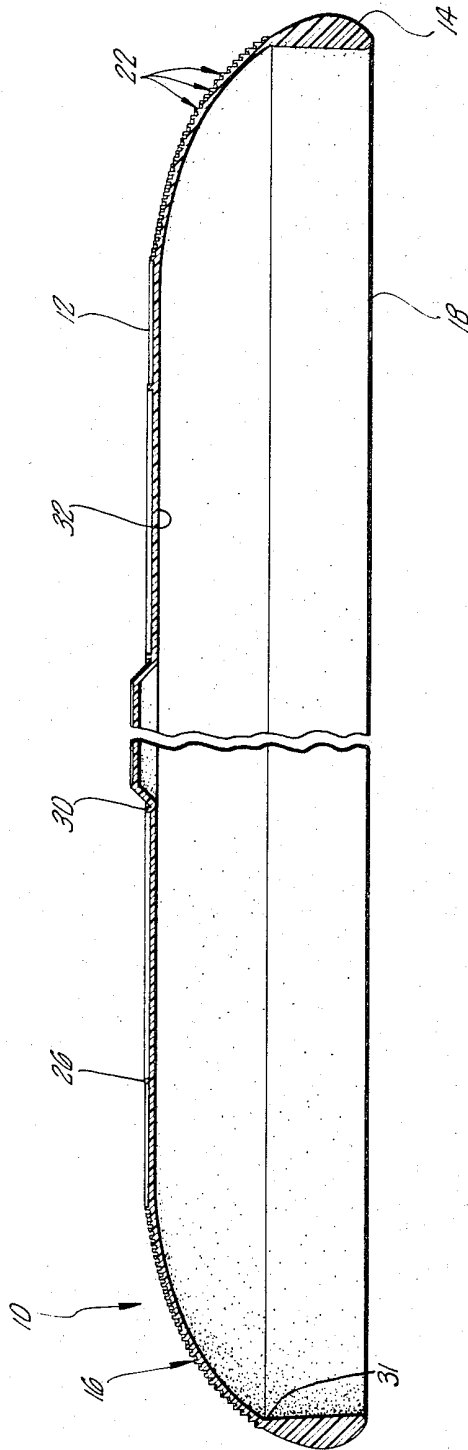

FIG. 4-

INVENTOR.  
EDWARD E. HEADRICK  
BY  
*Christie, Parker & Hale*  
ATTORNEYS.

1

3,359,678

**FLYING SAUCER**

Edward E. Headrick, La Canada, Calif., assignor to Wham-O Manufacturing Company, San Gabriel, Calif., a corporation of California  
 Filed Nov. 1, 1965, Ser. No. 505,864  
 3 Claims. (Cl. 46-74)

**ABSTRACT OF THE DISCLOSURE**

A saucer shaped throwing implement. A series of concentric discontinuities are provided adjacent the rim on the convex side of the implement. The discontinuities provided on the convex side of the implement exert an interfering effect on the air flow over the implement and create a turbulent unseparated boundary layer over the top of the implement reducing areodynamic drag.

This invention relates to aerodynamic toys to be thrown through the air and in particular to flying saucers for use in throwing games.

Over the past several years toys resembling saucers have become quite popular as throwing implements. In the usual embodiment the implement is made of a plastic material in a saucer shape with a rim located around the edge of the saucer, the rim having a somewhat greater thickness than the saucer portion of the implement. The rim curves downwardly from the saucer and has a configuration such that the implement when viewed in elevation approximates the shape of an airfoil.

The toy is used in throwing games and is normally gripped by placing the thumb on the convex side of the saucer and one or more of the fingers on the concave side. Throwing is usually accomplished with a wrist snapping motion wherein the thrower assumes a stance approximately at right angles to the intended target and retracts his arm across his body. By uncoiling his arm and snapping his wrist, momentum and a spinning motion is imparted to the saucer to cause it to fly toward the target. The direction of flight from the thrower depends upon the thrower's skill and the type of flight path (e.g. curved or straight) depends upon the angle of the saucer relative to the ground when it is released by the thrower. Its appeal as a toy appears to reside in the fact that it exhibits definite aerodynamics characteristics, can be made to do maneuvers of various kinds depending upon the skill of the user, and is relatively easy to master.

The present invention provides an improved version of this well-known flying saucer. In this invention, means located on the convex side of the flying saucer are provided for interrupting the smooth flow of air over this surface. In aerodynamics this action is described as "spoiling" the air flow and the means by which this is accomplished are described as "spoilers." As applied to the present invention, this disruption of airflow is thought to create a turbulent unseparated boundary layer over the convex side of the saucer and to result in a reduction of drag especially in high-speed flight and an increase in stability while in flight. This means that a novice thrower can learn to throw the flying saucer more rapidly, that more expert throws will result with less experience, that better accuracy can be achieved and that a reduction in the skill required to use the saucer is made possible.

The invention contemplates an aerodynamic toy. The toy comprises a central portion and a rim circumscribing the central portion and curving downwardly from the central portion. The central portion and the rim together form a concave side and a convex side of the toy. In addition, means are located on the convex side of the toy

2

for interfering with the flow of air over this side of the toy when it is thrown. The toy is of a size to be readily gripped with one hand for throwing and for this purpose has a rim height which permits convenient gripping of the implement with fingers placed on the first side of the implement and the thumb placed on the opposite side.

The invention will be better understood by reference to the following figures in which:

FIG. 1 is an elevational view of the flying saucer;

FIG. 2 is a view of the top or convex side of the flying saucer;

FIG. 3 is a view of the bottom or concave side of the flying saucer; and

FIG. 4 is a cross-sectional view taken along the lines 4-4 of FIG. 2.

Referring now to FIG. 1 there is shown an elevational view of a flying saucer 10 of this invention. As can be observed from FIG. 1, the toy resembles an inverted saucer having a central portion 12 and formed integrally therewith is a rim 14. To provide a smooth transition from the central portion 12 to the rim 14, a curved surface 16 is provided. The central portion 12, surface 16 and rim 14 together form two sides of the toy which will be referred to herein as the concave and convex sides of the toy.

As can be observed from FIG. 1, the bottom edge 18 of the saucer 10 together with the convex side of the toy resemble an air foil. A plateau or crown 20 is formed in the central portion 12 on the convex side of the toy. Although its contribution to the flight of the saucer has not been definitely determined, it is believed that the crown 20 also contributes to the stable flight of the saucer through the air.

Also shown in FIG. 1 are a plurality of ridges 22 superimposed or raised on the curved surface 16. As will be discussed in more detail below, the placement of ridges on the convex side of the saucer has been found to produce a beneficial effect on the stability of the implement when thrown. This stability is thought to be due to the ridges causing an effect which is analogous to the effect of a "spoiler" as that term is used in aerodynamics.

In FIGS. 2 and 3 are shown plan views of the convex and concave sides of the implement 10. As can be readily observed from FIGS. 2 and 3, the implement is circular in form. The rim 14 is placed so that it circumscribes the circular central portion 12 of the saucer. Further details of the relationship of the ridges 22 to the flat central portion 12 and the rim 14 can be seen from FIG. 2. The outermost ridge is located on the curved portion 16 in the area where the rim 12 and central portion 14 merge. The outermost ridge and any others which may be provided circumscribe at least a major portion of the periphery of the saucer. The other ribs or ridges 22 which are provided are located in concentric arrangement interiorly of this outermost ridge and in close juxtaposition with adjacent ridges as shown.

Another discontinuity 26 in the convex surface of the toy, also in the form of a rib or a ridge, is located interiorly of ridges 22 and forms a closed circle on the central portion 12 concentric with the center 28 of the saucer. Interiorly of ridge 26 is a ridge 30 marking the beginning of crown 20. Crown 20 resembles a circular plateau and is located on the central portion 12 of the saucer with its center coincident with the center 28 of the implement.

FIG. 3 depicts a view from the concave side of the saucer and as shown therein has a relatively smooth surface 32 extending from the rim 14 interiorly to the crown 20. Circle 34 corresponds to the ridge 30 located on the convex side of the saucer. In this view the crown appears as an indentation in the concave side of the saucer.

In FIG. 4, a section view taken along lines 4—4 of FIG. 2, further details of the relation of the rim 14 to the central portion 12 are shown. As shown the lower side of toy is concave and merges into the rim at 31. On the upper side the circular portion 12 is connected to the rim 14 by means of the curved transitional area 16 on which a plurality of ridges 22 have been placed. In addition, as can be observed, the thickness of the rim portion 14 is substantially greater than the thickness of the central portion. In the preferred embodiment the rim 14, ridges 22 and central portion 12 are formed integrally from plastic or other lightweight material by means of a molding operation.

The height of the rim 14 is selected such that the implement may be conveniently gripped by placing the thumb on the convex side of the saucer with the finger or fingers of the hand extending around the rim and being placed on the concave side of the saucer. It has been found that when the implement is thrown in a manner such that the saucer is approximately horizontal with respect to the ground as it leaves the hand that it displays definite aerodynamic properties and tends to "fly" in the direction in which it is thrown. It is believed that the saucer flies because the saucer approximates an airfoil and hence its flight through the air is enhanced by aerodynamic lift. Depending on the skill of the throwers the angle of the saucer with respect to ground can be varied to obtain greater eccentricities in flight such as causing the saucer to curve in one direction or another. Similarly the angle of attack with respect to the air can be varied such that if the saucer is thrown at a high angle of attack relative to the wind or airflow, the saucer can be made to demonstrate an action similar to a boomerang.

As indicated in a preceding discussion, the ridges 22 provided on the convex side of the saucer have been found to result in an improved flight of the saucer regardless of the skill of the thrower. This improved flight is not completely understood but is thought to be due to an effect analogous to a spoiler on an airfoil which interferes or interrupts the smooth aerodynamic flow over the top of the saucer. Put another way, the ridges or spoilers cause a disruption of the normal airflow pattern over the top of the saucer. This interference with the smooth airflow pattern results in a reduction in drag and an increase in stability, especially under high-speed flight conditions. The increase in stability under high-speed flight conditions is highly desirable since slight mistakes in execution of a hard throw tend to be exaggerated under these conditions. Due to the fact that the spoilers are provided and stability is thereby increased, the chances of a poor flight due to a hard or high-speed throw are reduced.

In addition to the various methods of throwing here-

tofore discussed, the saucer can also be used to perform other maneuvers. For example, a high, easy throw of the saucer causes it to stall and float downward gently as lift forces resist the pull of gravity. This floating action enables someone participating with the thrower to easily catch the toy as it settles vertically. Similarly, the throw can be executed by a throw in which the thrower begins with the toy behind his back and carries it in a vertical plane past the thigh and then rotates the wrist such that the saucer is brought to a nearly horizontal plane and released with a flip of the wrist in a relatively horizontal orientation causing it to fly away from him.

Although the spoilers which for the basis of the improvement in the saucer with which this invention is concerned have been shown to be circular ribs or ridges circumscribing the periphery of the saucer, various modifications and embodiments of such spoilers are believed to be possible. Provision of other means for interrupting the normal airflow pattern over the convex side of the saucer are possible without departing from the scope of the invention as determined by the following claims.

What is claimed is:

1. An aerodynamic toy comprising:

a circular central portion having a center surrounded by a substantially flat circular surface area whose boundary is defined by a predetermined radius; a rim circumscribing the circular central portion; a surface of curvature extending from said boundary and curving downwardly to a point of juncture with said rim to form an upper convex surface and a lower concave surface of the toy; and

air flow spoiling means located on the convex surface of curvature and extending substantially from said boundary to the point of juncture at the rim, said spoiling means comprising a plurality of concentric circular raised ribs being concentric about said center.

2. A toy according to claim 1 wherein said plurality of raised ribs are evenly spaced.

3. A toy according to claim 1 wherein the rim has a greater thickness than the body portion.

#### References Cited

##### UNITED STATES PATENTS

D. 183,626	9/1958	Morrison	34—15
356,929	2/1887	Cruttenden et al.	273—105
2,659,178	11/1953	Van Hartesveldt	46—74
2,835,073	5/1958	Dame	46—74

RICHARD C. PINKHAM, *Primary Examiner*.

ANTON O. OECHSLE, F. BARRY SHAY, *Examiners*.

T. ZACK, *Assistant Examiner*.